



Product guide

Heating homes has never been easier

www.atlantic-heat.co.uk

Find the answer to your heating needs



Comprehensive business support

With a range of tools to help you grow your business, Atlantic Heat is on hand to ensure you have the support you need.
We are available to take your calls Monday to Thursday 8.30am to 5pm and Friday 8am to 4.30pm.
Helpline: 0844 3350 549



Quick & easy

With Click & Go functionality, installation is fast and stress-free – perfect for when you’re installing large quantities for major projects.



Complete design process

Electric heating can be installed in most domestic and light commercial applications, our comprehensive design service provides a full plan for architects and specifiers.



Product reliability

Atlantic Heat products are founded on more than 40 years of heating innovation. You can be sure that each product delivers reliability as standard.

Agilia Digital

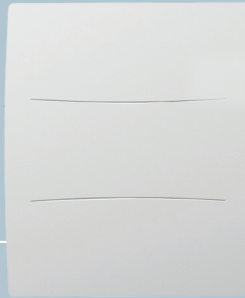

- Open window detection
- 2 modes: Manual/Programmable
24 hour 7 day timer

See more **P08**

CLICK AND GO RAL9016 White

Accessio



- Fitted with user-friendly digital controls driving energy savings
- 6-command pilot wire: Comfort -1°C, Comfort -2°C, Eco, Frost-free, Off

See more **P12**

CLICK AND GO RAL9016 White

Oniris

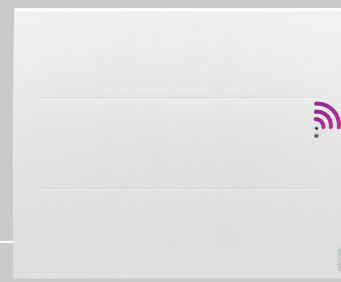

- Absence & Presence detection
- 45% of radiant heating, faster warm up

See more **P20**

CLICK AND GO RAL9016 White COZYTOUCH atlantic

Tatou

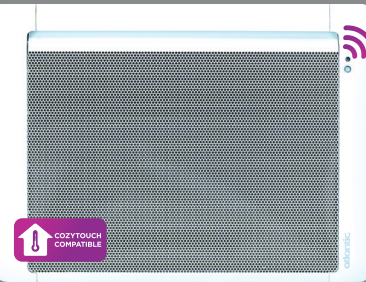

- Absence & Presence detection
- Open window detection

See more **P14**

CLICK AND GO RAL9016 White COZYTOUCH atlantic

Timelis

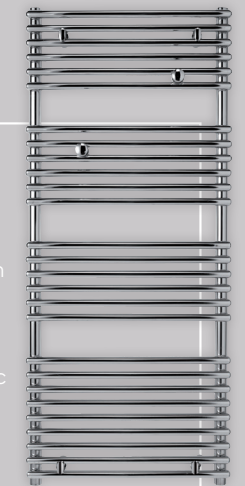

- 25% energy savings* through integrated programming
- Digital electronic thermostat

* Compared to a mechanical convector

See more **P26**

CHROME

F127



- Open window detection
- 2 modes: Manual/Programmable
24 hour 7 day timer

See more **P06**

CLICK AND GO RAL9016 White

Galapagos



- COZYTOUCH COMPATIBLE
- Tracks the user's requirements adapting heating accordingly
- Switches heater to minimum when window is opened

See more **P16**

CLICK AND GO COZYTOUCH atlantic RAL9016 White 481 Anthracite Grey

Agilia io

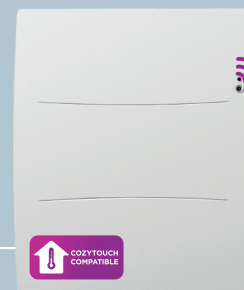

- Absence & Presence detection
- Open window detection

See more **P10**

CLICK AND GO RAL9016 White COZYTOUCH atlantic

Contents

As part of Groupe Atlantic, the Atlantic electric heating brand is synonymous with quality and efficiency.

We understand that you need a partner who has the skills and expertise to deliver a wide range of reliable heating solutions to suit your needs.

Developed with the installer and end user in mind, we combine premium design with cutting edge technology to bring you a wide range of easy-to-install and reliable heating systems.

Our products are founded on more than 40 years of electric heating innovation and with convector, radiant & connected heating solutions, there's an extensive range to suit everyone's requirements.



1	Contents page	p03
2	Designed with you in mind	p04
3	F127	p06
4	Agilia Digital	p08
5	Agilia IO	p10
6	Accessio	p12
7	Tatou	p14
8	Galapagos	p16
9	Oniris	p20
10	CozyTouch, IO Home Control & Smart Pilot	p22
11	Timelis	p26
12	Why choose electric heating?	p28
13	Electric heating explained	p30
14	Bathroom Regulations	p31

Designed with you in mind



With a range of features including easy installation at second fix stage and energy efficient controls, all Atlantic electric heating products are designed with both the installer and end user in mind.

For ultimate home comfort each product in the range comes with integral, easy to use heating controls, with some electric heaters even featuring energy saving smart technology which adapts heating depending on room occupancy.



Designed with you in mind

- Quick and easy installation at second fix stage or later – ideal for new developments, renovation or refurbishment projects
- No annual service required
- Complete reliability with minimal moving parts
- Energy savings when compared with conventional heating
- 100% efficiency at the point of use
- Design freedom – electric heating can be installed virtually anywhere
- Highly accurate electric thermostats
- Innovative energy saving heating controls
- App based heating control option*
- ErP (Lot20) compliance

*Where applicable



*Where applicable

F127

Electric Panel convector

2 YEAR
WARRANTY



Description

- 6 models: 500 to 2000 kW
- Built in energy saving features
- Manual or Programmed
- Open window detection
- Colour: RAL9016 White



The F127 is an active heat convector with easy to use controls that is suitable for a range of applications. The F127 allows 24 hour, 7 days a week programming to cover a multitude of situations. With its simple design and easy fixing it's perfect for anything from a single, to high volume installations.



Key features

- Open window detection
- 2 modes: Manual/Programmable 24 hour 7 day timer
- High-precision electronic thermostat
- Ergonomic LCD digital controls
- Up to 25% energy savings*
- Sheathed heating element with an aluminium diffuser (safe, silent and long-lasting)
- Automatic over heat safety device
- Front air outlet wings
- Class II and IP24 protection with dual electric insulation for ultimate safety

*compared with a mechanical convector

Dimensions

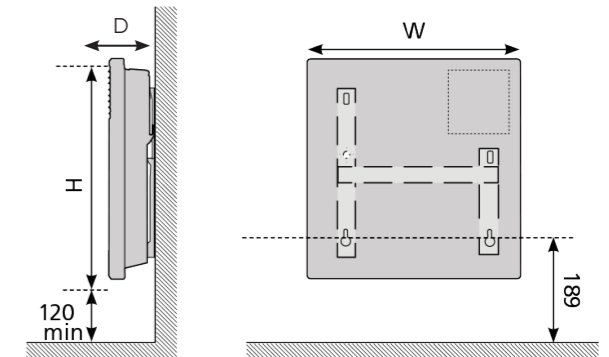

F127 technical data

OUTPUT (W)	DEPTH (MM)	WIDTH (MM)	HEIGHT (MM)	WEIGHT (KG)	MODEL
500	102	370	453	3.8	AH500101
750	102	370	453	3.8	AH500106
1000	102	447	453	4.2	AH500103
1250	102	517	453	4.4	AH500107
1500	102	590	453	5.5	AH500104
2000	102	740	453	6.8	AH500105

Agilia Digital

Electric radiator

2 YEAR WARRANTY

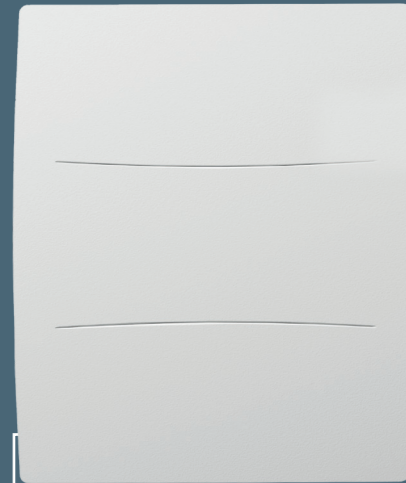

Description

- 6 models: 500 to 2000W
- Built in energy saving features
- Colour: RAL9016 White



The Agilia Digital is a compact radiator in a stylish design with a double heating element for fast warm up and homogeneous heating. The Agilia Digital can be used in basic mode, which allows for easy control and gives flexibility to the user ensuring the heating is right for them. Alternatively use the Agilia in programmed mode with the user set times and temperatures.



Key features

- Open window detection
- 2 program modes 24 hour 7 day timer
- High-Precision Electronic thermostat
- Digital screen, LCD digital controls
- Stylish electric radiator with double heating element for fast heating
- Energy consumption indicator
- Anti frost comfort and eco functions
- Lock function

Dimensions

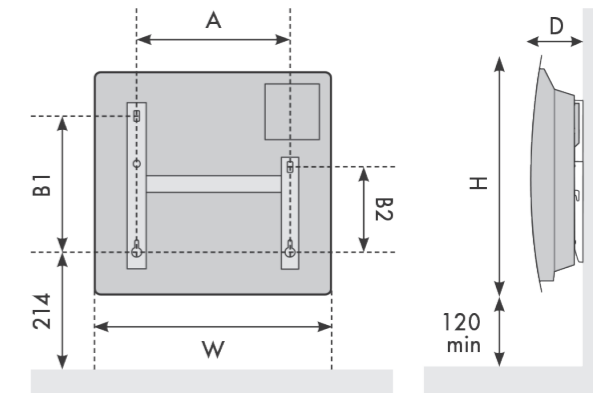

Agilia technical data

OUTPUT (W)	DEPTH (MM)	WIDTH (MM)	HEIGHT (MM)	A	B1	B2	WEIGHT (KG)	MODEL
500	129	372	530	120.8	246	158.5	5.5	AH503205
750	129	372	530	120.8	246	158.5	5.5	AH503207
1000	129	446	530	194.8	246	158.5	6	AH503210
1250	129	520	530	268.8	246	158.5	7.5	AH503212
1500	138	594	530	342.8	246	158.5	9	AH503215
2000	138	742	530	490.8	246	158.5	9	AH503220

*Compared with a mechanical convector

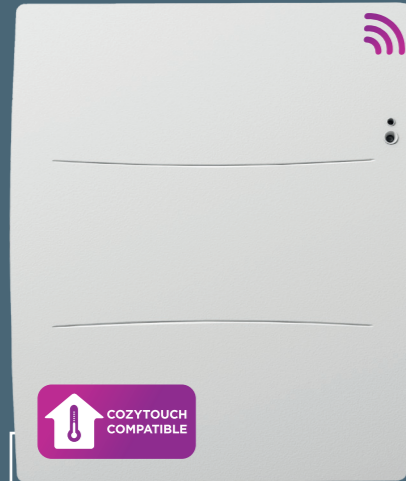

Description

- 6 models: 500 to 2000W
- Built in energy saving features
- Smart control functionality
- Colour: RAL9016 White



The Agilia IO takes the smart features of the Agilia Digital and adds Cozytouch compatibility allowing the user to control these features through their smartphone*. With integrated absence and presence detectors, the Agilia IO adapts to your lifestyle and, even in its stylish and compact form. It can also heat up quickly thanks to its double heating element.



Key features

- Open window detection
- Absence & Presence detection
- 3 programming modes manual, prog, (24 hour 7 day timer) and IO
- High-Precision Electronic thermostat
- Digital screen, LCD digital controls
- Stylish electric radiator with double heating element for fast heating
- Energy consumption indicator
- IP24 rated
- Lock function

Dimensions

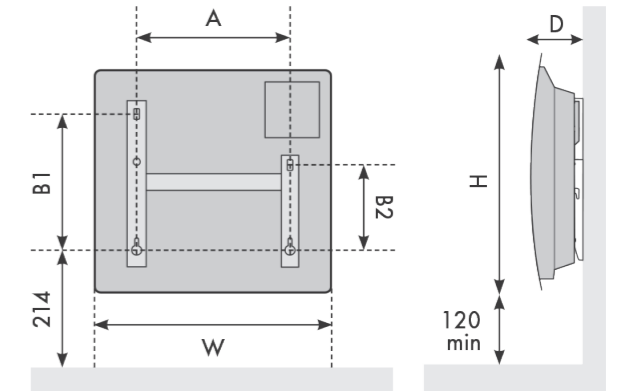

Agilia technical data

OUTPUT (W)	DEPTH (MM)	WIDTH (MM)	HEIGHT (MM)	A	B1	B2	WEIGHT (KG)	MODEL
500	129	372	530	120.8	246	158.5	5.5	AH503105
750	129	372	530	120.8	246	158.5	5.5	AH503107
1000	129	446	530	194.8	246	158.5	6	AH503110
1250	129	520	530	268.8	246	158.5	7.5	AH503117
1500	138	594	530	342.8	246	158.5	9	AH503115
2000	138	742	530	490.8	246	158.5	9	AH503120

* Compared with a mechanical convector

Accessio

Electric thermofluid radiator

2 YEAR WARRANTY



Description

- 7 models: 300 to 2000W
- Built in energy saving features
- User friendly
- Manual or Programmed
- Colour: RAL9016 White



The Accessio is an easy to use electric, heat conducting fluid-filled radiator that delivers homogeneous long-lasting heat as a result of integral thermofluid technology. Not only that, user friendly digital controls and an electronic thermostat can help homeowners achieve energy savings of up to 25% versus conventional electric heating solutions.*



Key features

- Open window detection
- 2 modes: Manual/Prog 24hour 7 day timer
- 6-command pilot wire: Comfort, Comfort -1°C, Comfort -2°C, Eco, Frost-free, Off
- High-precision electronic thermostat
- Up to 25% energy savings* through accurate digital control and programming
- Thermofluid technology providing homogeneous & long-lasting heat, and no dry air
- ASP (Anti-Staining Process) to reduce staining on wall and on equipment

Dimensions

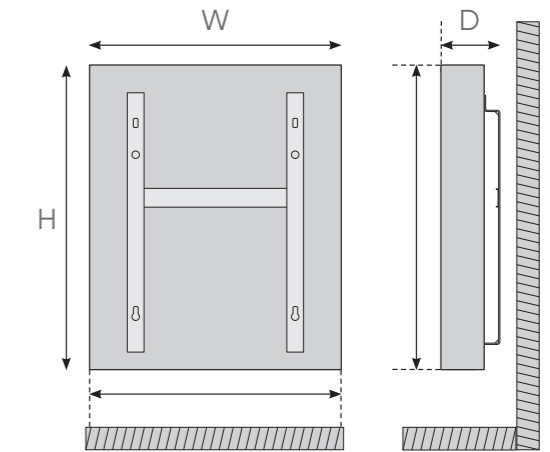

Accessio technical data

OUTPUT (W)	DEPTH (MM)	WIDTH (MM)	HEIGHT (MM)	WEIGHT (KG)	MODEL
300	127	410	575	8.5	AH524903
500	127	410	575	8.5	AH524905
750	127	490	575	9.9	AH524907
1000	127	490	575	9.9	AH524910
1250	127	651	575	13.2	AH524912
1500	127	732	575	14.8	AH524915
2000	127	973	575	19.7	AH524920

* Compared to a mechanical convector

Tatou

Radiant panel heater

2 YEAR WARRANTY

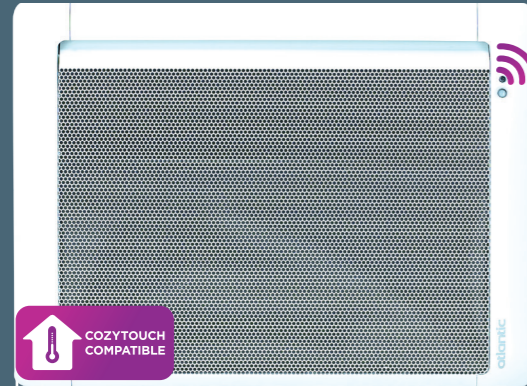

Description

- 9 models: 500 to 2000 W
- Built in energy saving features
- Smart control functionality
- Cozytouch compatible
- Colour: RAL9016 White



The Tatou is a digital radiant panel heater which is available in horizontal and vertical models. Using Infra Red technology it offers greater energy savings compared to a conventional electric heater. With absence and presence detectors, open window detection and a super sleek design means the Tatou heater is not only functional but stylish too. Bringing lasting, comfortable heat to your home.



Key features

- Smart control functions learning and adapting the energy consumption to the user's lifestyle
- Open window detection
- 6-command pilot wire: Comfort, Comfort-1°C, Comfort - 2°C, Eco, Frost-free, Off
- High-precision electronic thermostat
- Digital display unit
- Extensive heat panel with sensors, aluminium heating element
- Consumption indicator for responsible, informed use of the equipment
- Easy to install: H-shaped vertical support, which can also be used as an installation template
- ASP (Anti-Staining Process) to reduce staining on wall and on equipment
- Far Reaching Infra Red (FRIR) technology
- Standard and vertical to adapt to the customer's rooms

Tatou Digital

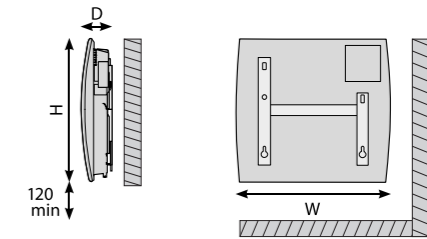

Tatou Vertical

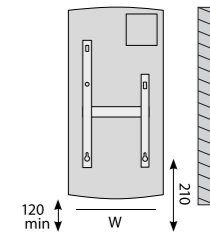

Tatou technical data

OUTPUT (W)	DEPTH (MM)	WIDTH (MM)	HEIGHT (MM)	WEIGHT (KG)	MODEL
500	120	465	470	4.3	AH566205
750	120	540	470	4.9	AH566207
1000	120	615	470	5.5	AH566210
1250	120	765	470	6.2	AH566212
1500	120	840	470	7.1	AH566215
2000	120	1060	470	10	AH566220

TATOU DIGITAL VERTICAL

1000	135	470	775	7.2	AH566410
1500	135	470	995	9.3	AH566415
2000	135	470	1220	11.3	AH566420

* Compared to a mechanical convector

Galapagos

Electric thermofluid radiator

2 YEAR
WARRANTY



Description

- 3 models: 700 to 2000W
- Built in energy saving features
- Smart control functionality
- Cozytouch compatible



The Galapagos is a stylish, electric, fluid-filled radiator that distributes uniform heat from its entire surface using thermofluid technology. The Galapagos electric radiator has an AUTO mode which is an in-built smart control function that tracks the user's requirements and room occupancy and adapts heating to comfort or eco mode accordingly. It also features open/closed window detection that switches the heater to a minimum output when a window is opened. The Galapagos has a stylish, curved aluminium front panel ideal for modern homes and kitchens.



Key features

- In built smart control function tracks the user's requirements and room occupancy, adapting heating to comfort or eco mode accordingly (AUTO mode)
- Open window detection
- 3 programming modes manual, prog, (24 hour 7 day timer) and IO
- High-precision electronic thermostat
- Thermofluid technology - heating element immersed in a heat transmitting fluid
- Consumption indicator for responsible, informed use of the equipment
- Class II and IP24 protection with dual electric insulation for ultimate safety
- ASP (anti-dust) technology
- Available in White and Anthracite



Galapagos Range

Electric thermofluid radiator



Standard

RAL9016 White
 481 Anthracite
 2 YEAR WARRANTY



OUTPUT (W)	DEPTH (MM)	WIDTH (MM)	HEIGHT (MM)	WEIGHT (KG)	A	B	WHITE MODEL	ANTHRACITE
750	130	670	590	12.4	300	354	AH500607	AH506144
1000	130	770	590	14.4	400	354	AH500610	AH506244
1250	130	970	590	18.4	600	354	AH500612	AH506344
1500	130	1070	590	20.4	700	354	AH500615	AH506444
2000	130	1370	590	26.4	800	354	AH500620	AH506544



Low height

2 YEAR WARRANTY

481 Anthracite

RAL9016 White

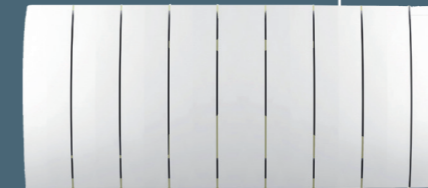

OUTPUT (W)	DEPTH (MM)	WIDTH (MM)	HEIGHT (MM)	WEIGHT (KG)	A	B	WHITE MODEL	ANTHRACITE
700	133	771	388	11	400	158	AH502907	AH502144
1000	133	971	388	15	600	158	AH502910	AH502244
1400	133	1371	388	21	800	158	AH502915	AH502344

Standard

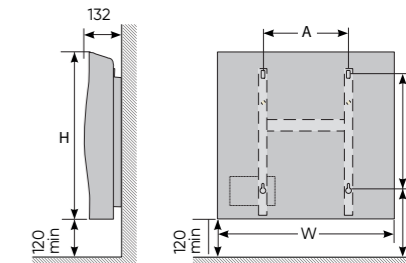

Low height

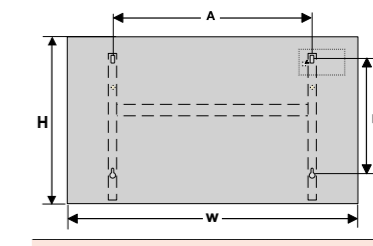

Vertical

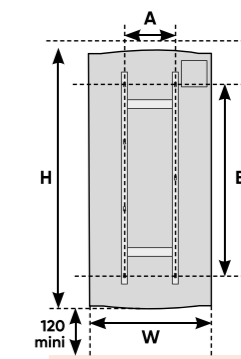

Vertical

RAL9016 White

2 YEAR WARRANTY

481 Anthracite



OUTPUT (W)	DEPTH (MM)	WIDTH (MM)	HEIGHT (MM)	WEIGHT (KG)	A	B	WHITE MODEL	ANTHRACITE
1000	133	460	1290	24	320	1021	AH501310	AH501644
1500	133	460	1590	29	320	1321	AH501315	AH501744
1800	133	460	1800	33	320	1521	AH501320	AH501844

Oniris

Electric radiator

2 YEAR WARRANTY

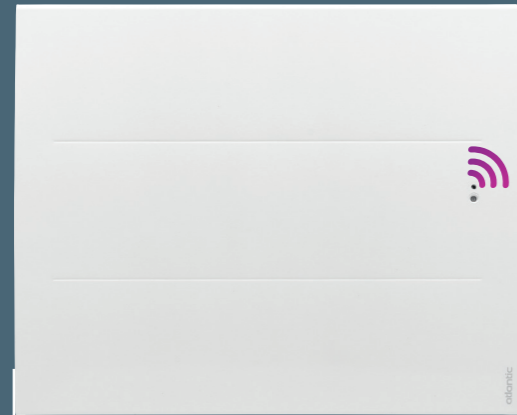

Description

- 5 models: 750 to 2000W
- Built in energy saving features
- Smart control functionality
- Compatible with CozyTouch
- Colour: RAL9016 White



The Oniris is a very stylish, digital, electric panel heater featuring a modern aluminum surface and heating element for warmth with style. Complete with occupancy detection, which automatically reduces heat if the room is empty, and open window detection that will switch the heater to a minimum output.



Key features

- In built smart control function tracks the user's requirements and room occupancy, adapting heating to comfort or eco mode accordingly (AUTO mode)
- Open window detection
- Presence / absence detection feature – will automatically reduce heat if room is empty
- 3 programming modes manual, prog, (24 hour 7 day timer) and IO
- High-precision electronic thermostat
- 45% of radiant heating, faster warm up
- Aluminium heating element with additional heating film
- Consumption indicator for supreme energy efficiency
- IP24 rated

Dimensions

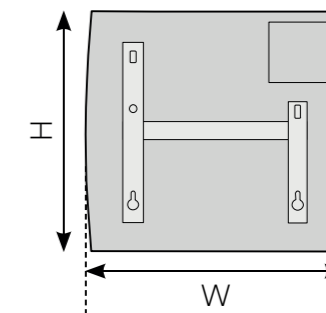
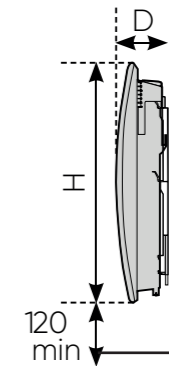

Oniris technical data

OUTPUT (W)	DEPTH (MM)	WIDTH (MM)	HEIGHT (MM)	WEIGHT (KG)	MODEL
750	110	613	615	10.8	AH503907
1000	110	761	615	13	AH503910
1250	110	909	615	15.4	AH503912
1500	110	1058	615	18	AH503915
2000	110	1205	615	20.4	AH503920

Cozytouch

APP AVAILABLE TO DOWNLOAD FOR FREE!

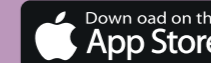

key features

- Bridge allows control of connected Atlantic products
- LED indicator
- Connects to internet router via supplied ethernet cable
- User account required (on set up)
- Prog/Prog reset button
- Power supply lead included

Cozytouch requires internet connection



Cozytouch allows you to control your heating remotely from your phone or tablet. Offering real-time monitoring such as energy consumption, absence detection and open window detection, Cozytouch means you can set the temperatures you want for when you want them.

Technical data

DEPTH (MM)	WIDTH (MM)	HEIGHT (MM)	MODEL
110	71	28	AH001231

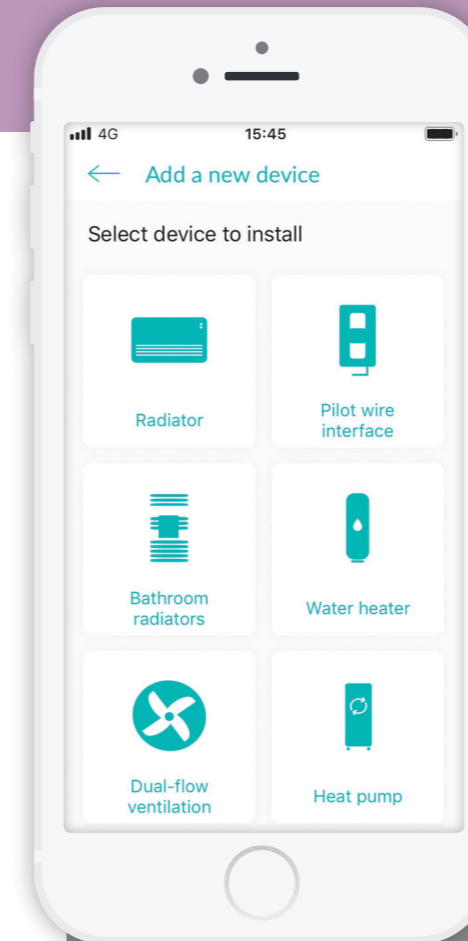
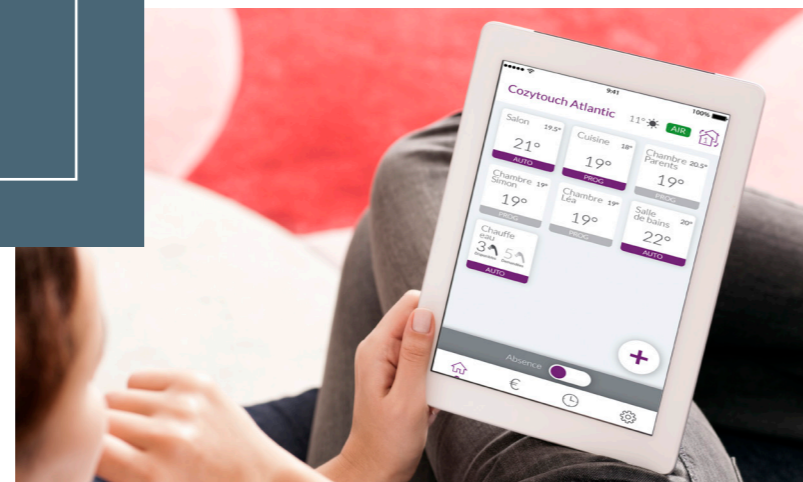

Here are just a few of the features of the Cozytouch smart app:

- Real time monitoring
- Absence detection
- Daily energy management
- Synchronize temperatures
- Open window detection
- Control individual or multiple paired devices



Compatible with*

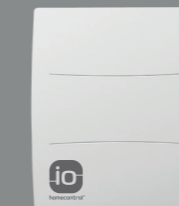

Agilia IO

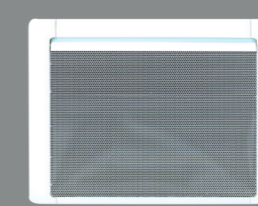

Tatou

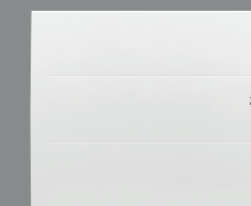

Oniris



Galapagos

*Pairing function available on all IO compatible heaters

A simple move and the panel heater takes care of everything. With the Smart Pilot function, the appliance automatically adapts to the user's lifestyle, to deliver optimum comfort and maximum energy savings.

Memorises the user's lifestyle

Identifies, analyses & memorises presence periods.

Anticipates heating

According to the user's lifestyle, ensuring that the room is already at the right temperature upon arrival.

Adapts to unforeseen events

Identifies, analyses & memorises presence periods.

Auto & dynamic programming

Automatically, the light & movement sensor adjusts the program to your presence / activity in the dwelling for each day.

Warm-Up time auto calculation

The radiator will calculate how long it takes to warm the room where it is installed. Default value is 90 mins and can be adjusted for from either 20mins to 3 hours.

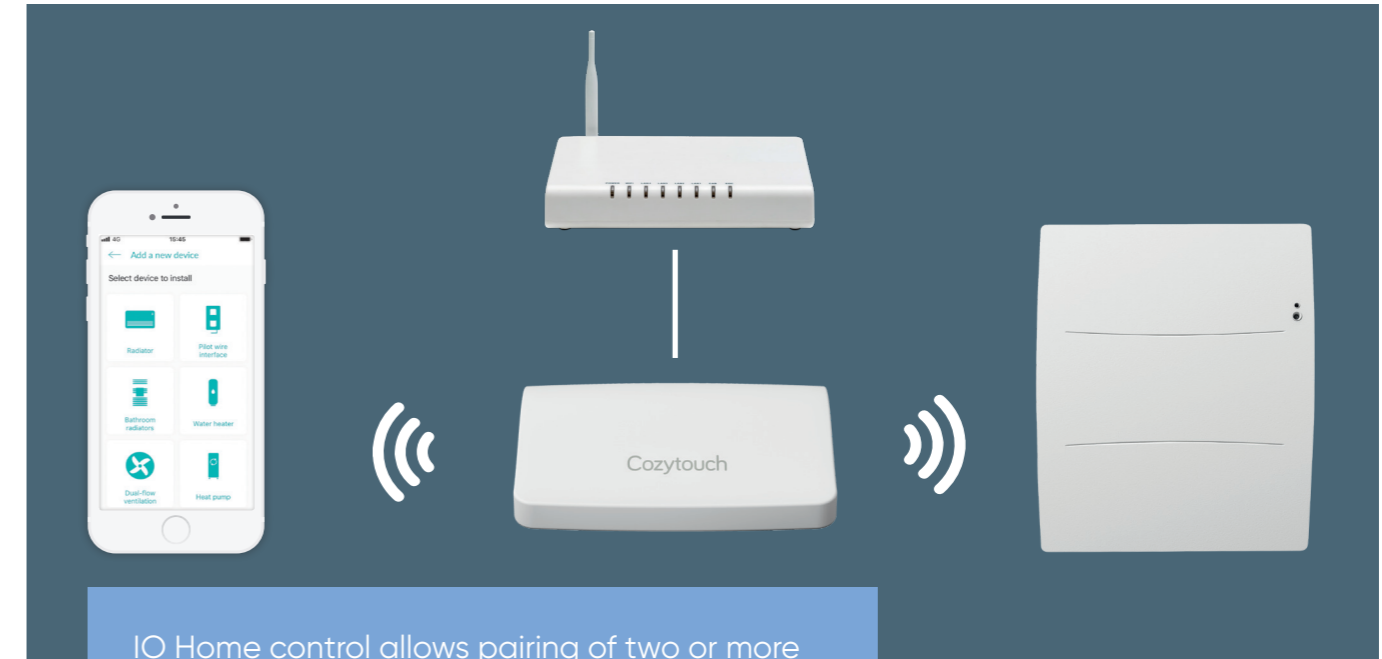

IO Home control allows pairing of two or more heaters allowing greater comfort in your home

Pair heaters in the same room or on each floor to give greater control of your heating

Combined smart functionality - once paired, if a device in the group detects an open window, the other paired products react accordingly saving you energy

Couple IO Home control with the Cozytouch device to control your home remotely room by room, panel by panel

Timelis

Electric towel dryer

2 YEAR WARRANTY



key features

- £ 25% energy savings* through integrated programming
- 🕒 Digital electronic thermostat
- CE IP24 rated
- ErP ErP compliant Towel Warmer

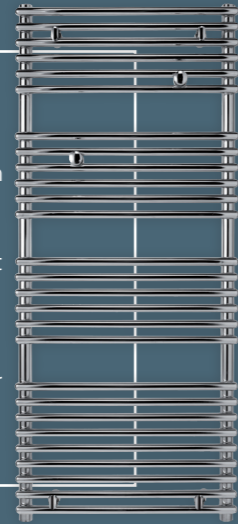

The Timelis towel drier uses thermofluid technology and has been designed for comfort and simplicity. Timelis features a remote control with integrated programming, an integral, adjustable thermostat with eco and comfort modes, a two-hour boost override and a push button set function.

Dimensions

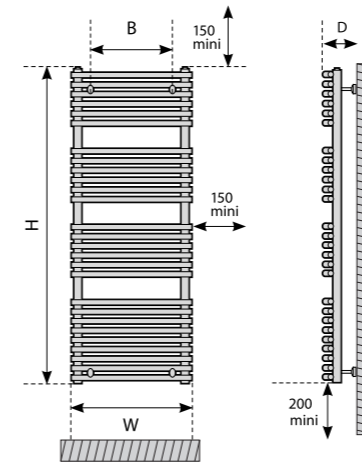

Timelis technical data

OUTPUT (W)	DEPTH (MM)	WIDTH (MM)	HEIGHT (MM)	WEIGHT (KG)	MODEL
300	110	555	984	19	AH952103
500	110	555	1374	25	AH952105
750	110	555	1764	34	AH952107

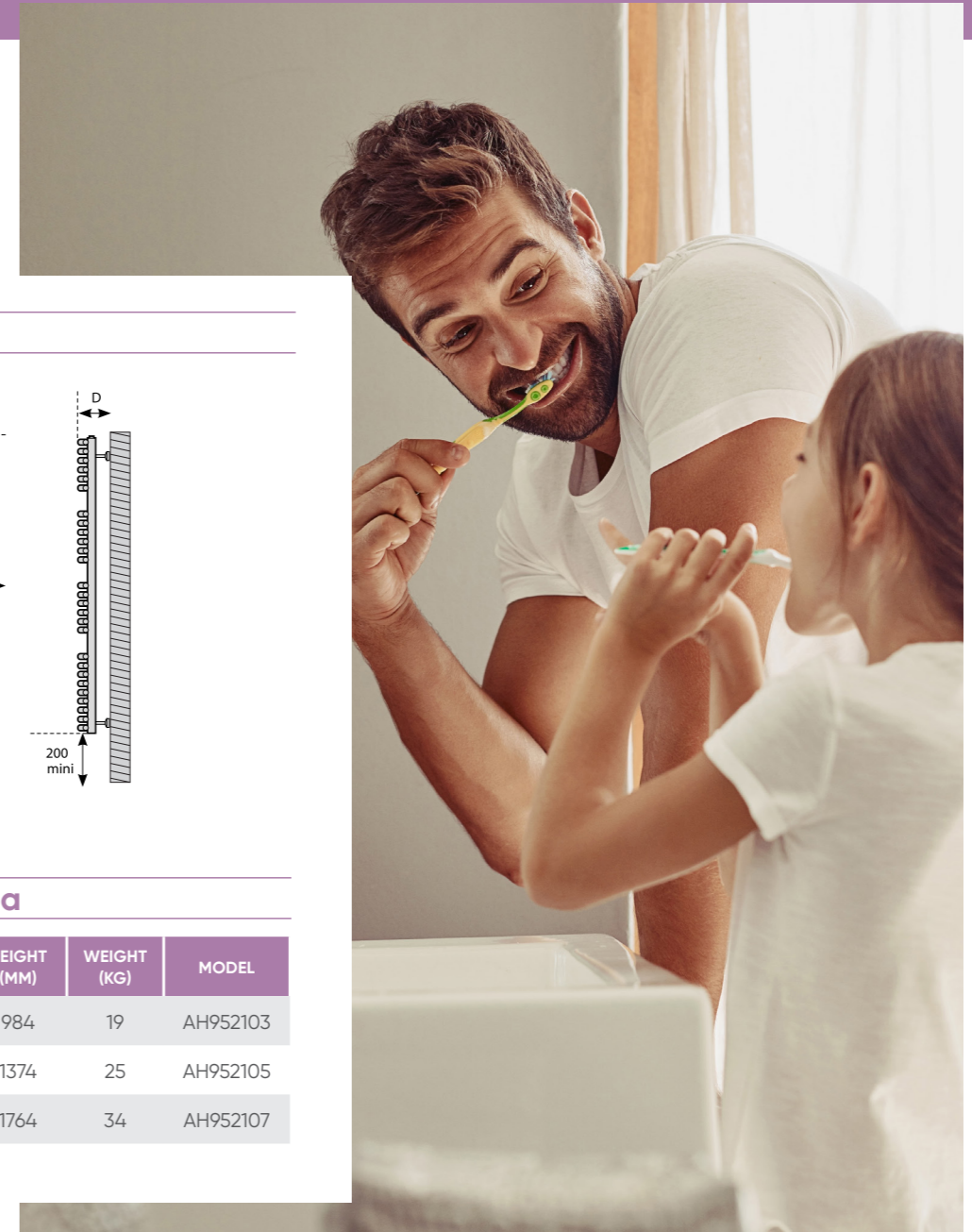

* Compared to a mechanical convector



Remote control



Why choose electric heating?

Electric heaters are 100% efficient at the point of use, meaning all electricity used is converted into heat.

Because electric heaters have virtually no moving parts, most systems can provide great longevity and reliability than alternative ways of heating.

The Energy related Product (ErP) Directive aims to reduce carbon emissions across Europe by phasing out low efficiency products, for electric heating the directive requires that local space heaters comply with the minimum efficiency standard.

Here is our ErP compliant promise to you:

- ✓ Our heaters perform to a high efficiency saving you energy and money on bills.
- ✓ All heaters will include open-window detection offering additional control to save energy.
- ✓ Every heater has an integral temperature control which offers 24 hour and 7 day timers.
- ✓ Users can benefit from additional smart functions from distance heating control and monitoring via the Cozytouch app.



Future Proofing

Electric heaters can provide a major advantage in home extensions when existing gas central heating systems lack sufficient capacity to heat additional radiators.



Electric heating

Electricity is increasingly being produced from renewable sources reducing the level of carbon intensity. Thermal losses and associated energy consumption have considerably reduced as a result of improvements to the fabric of buildings. Electric heating provides a solution that is 100% efficient at the point of use where every kWh paid for is converted into heat. Electric heating can be controlled with a higher degree of accuracy than other systems offering room by room control which can react quickly to supplementary heat gains, electric heating requires almost no annual maintenance whilst offering greater reliability and a lower capital installation cost.

Convected heat

Convected heat is carried around a room in the form of heated air. Air is drawn across a heating element inside the electrical heater and circulated into the room. Heated air is lighter and diffuses the colder air which is denser and raises the ambient temperature. The hotter the electric heater's heating element, the further the convected heat will flow before diffusing into the air.

Building Regulations

Building Regulations Approved Document Part L demands that appropriate steps are taken for the conservation of energy by limiting heat loss and heat gain through the material of a home as well as addressing the efficiency of heating, lighting and ventilation. Part L1A applies to the conservation of fuel and power in new dwellings in England. Part L1B applies to conservation of fuel and power in existing dwellings in England. Part L1A requires that reasonable provision is made for the conservation of fuel and power in buildings by limiting heat gains and losses through thermal elements and other parts of the building fabric and providing fixed building services that are energy efficient and have effective controls to ensure they use no more power than is reasonable in the circumstances.

Radiant heat

Unlike convected heat, radiant heat does not rely on the direct heating of air. It relies instead on electromagnetic infrared waves which transfer the energy and release it as heat once it strikes an object. It's this type of heat we get from the sun and an open flame.

Safety

Because electric heaters do not burn fuel internally to generate heat, there are none of the associated risks such as carbon monoxide poisoning. This gives electric heaters a greater margin of safety over conventional central heating systems and there is no requirement for an annual safety certificate.

Cost

Electric heating and hot water solutions can be a preferred choice amongst housing professionals in certain installations such as flats and apartments due to lower capital costs, faster installation times and system layout flexibilities when compared to conventional heating systems. It is entirely suited to second stage fixing in new builds or for renovations with minimal disruption relying only on a simple connection to the electrical circuits. An electric heater can be installed in matter of minutes and can be operated independently or as part of a heating system.

Electric heating explained



IP rating

IP stands for Ingress Protection and are ratings that define the levels of sealing effectiveness of electrical equipment against moisture and foreign bodies, such as dirt and dust.

Each IP rating is defined by two numbers (e.g. XY) which have a specific meaning. The first number (X) indicates the level of mechanical protection and the second number (Y) defines the level of moisture protection. In both cases, the higher the number, the better the protection. If an item of electrical equipment is not IP rated, it must not be used in Zones 0, 1 or 2.

Typical electrical items which are marked with IP numbers include heaters, extractor fans, lighting, shower pumps and electric showers. Most Atlantic electrical products have a rating of IP24.



Pilot wire

Many Atlantic products have a pilot wire. This is a black insulated lead in the mains cable which is used for signalling or switching when connected to a suitable GIFAM compatible pilot wire controller (ErP compliant). This wire must not be connected to earth.

Double insulated

Atlantic products are double insulated (Class II). Products are designed in such a way so as not to require a safety connection to earth. These products must not have a safety connection to earth.

Product reliability

The CE mark is the manufacturer's declaration to appropriate enforcement authorities that the product complies with all relevant European directives, such as the Low Voltage Directive for Safety and the Electromagnetic Compatibility Directive for Radio Interference and ErP. Atlantic Heat products comply with the European Directive and carry the CE mark.

Bathroom regulations



Safety is paramount when using electrical equipment in bathrooms and wet areas. The NICEIC Wiring Regulations (17th Edition) identifies particular zones within the bathroom to indicate what type of electrical equipment can be installed. The regulations state that electric appliances installed inside Zones 1 and 2 must have a rating of IPX4 (see bathroom illustration). Atlantic products have a rating of IPX4 or greater.

Bathroom zones are identified from 0 to 2, with 0 being the wettest. The former Zone 3 is now undefined. Any electrical item approved for use in a zone may be used in another zone with a higher number but not in a lower number zone.

A bathroom heater must comply with ErP regulations.

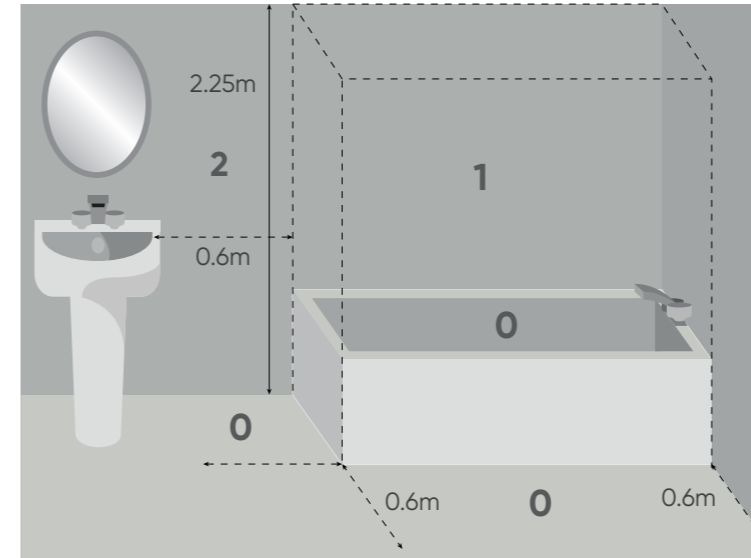

Zone 0

The interior of a bath or shower which can hold water.

Requires low voltage (max 12V) electrical products and to be IPX7 (the mechanical protection is unimportant).

Zone 1

The area directly above Zone 0 limited vertically to 2.25m above the bottom of the bath or shower.

Requires electrical products to be IPX4 or better, or Safety Extra Low Voltage (SELV) with the transformer located beyond Zone 2. If the fitting is 240v, a 30mA RCD must protect the circuit.

Zone 2

The area beyond Zones 0 and 1, 0.6m horizontally and 2.25m vertically.

Zone 2 also included any window with a sill next to the bath. Requires electrical products to be IPX4 or better, or SELV with the transformer located beyond Zone 2.

Zone 3

The area beyond Zone 2 previously referred to Zone 3 is now undefined.

When a bathroom extends 3 metres beyond Zone 1, portable equipment is permitted. Any socket used for this portable equipment must be protected by a 30mA RCD.



atlantic-heat.co.uk

AH2019-001-V1

T: 0844 3350 549 F: 0844 5436 180
E: enquiries@atlantic-heat.co.uk
Atlantic Heat | PO Box 103, National Avenue,
Kingston Upon Hull, HU5 4JN

Atlantic Heat is part of Ideal Boilers Limited. Ideal Boilers Ltd. pursues a policy of continuing improvement in the design and performance of its products. The right is therefore reserved to vary specification without notice.

 GROUPE
ATLANTIC
UK, ROI & NORTH AMERICA DIVISIONS